

EE160

HVAC Humidity and Temperature Transmitter

Specially designed for HVAC, the EE160 sensor by E+E Elektronik is a cost-effective, highly accurate and reliable solution for measuring relative air humidity and temperature.

The enclosure minimizes installation costs and provides outstanding protection against contamination and condensation, thus ensuring flawless operation.

The EE160 employs the new humidity/temperature E+E sensor element HCT01 with excellent long term stability and resistance against pollutants. In combination with a long calibration experience, the EE160 provides a measurement accuracy of $\pm 2.5\%RH$ and is available for wall or duct-mounted with current, voltage or Modbus RTU output.



A configurator makes it possible to freely select the scaling of the temperature output and configure the Modbus parameters. The configurator software, which is free of charge, allows additionally for an on-site adjustment of the humidity and temperature.

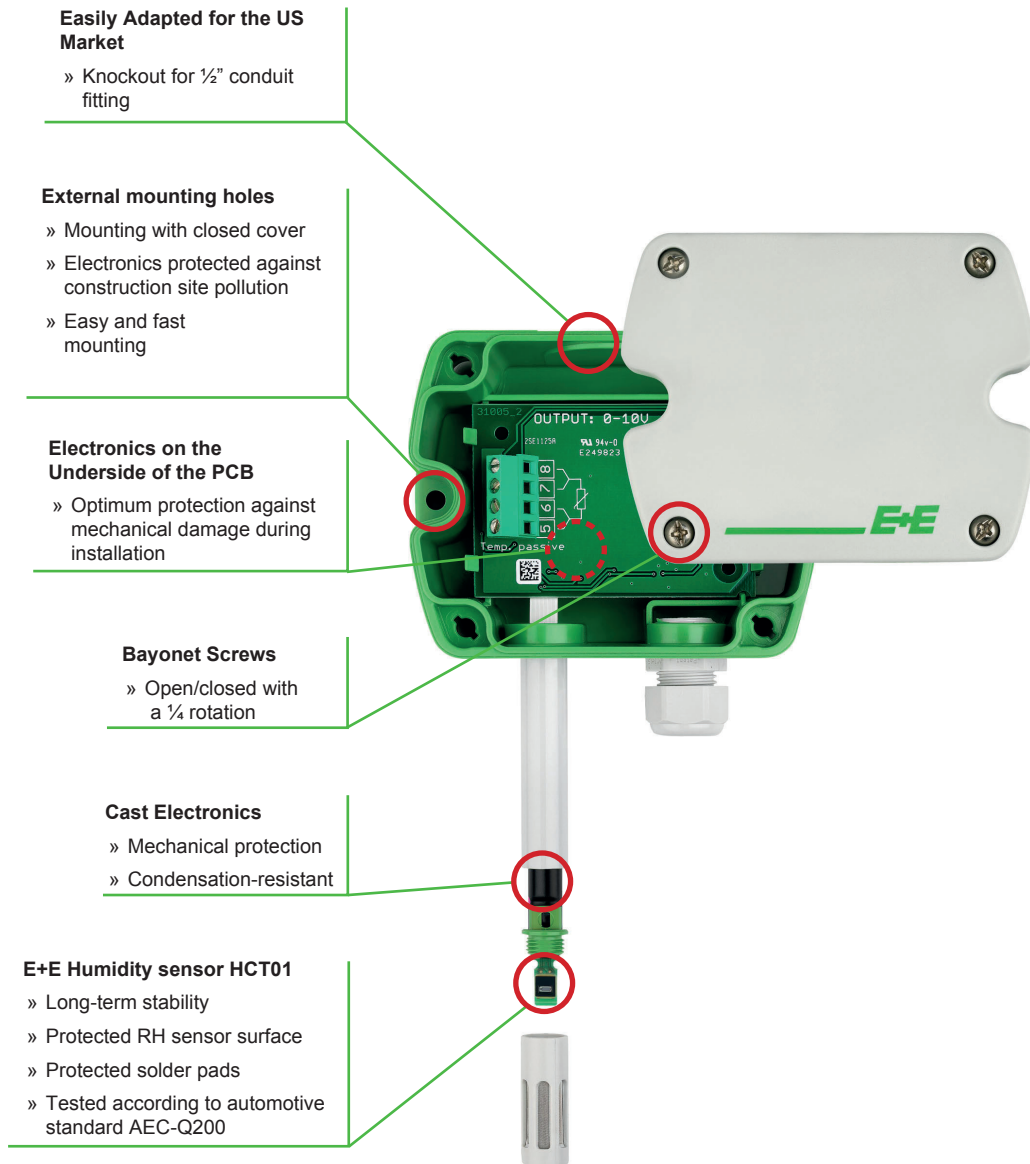

Technical data

Measured values

Relative Humidity

Sensor	E+E Sensor HCT01-00D	
Analog output 0...100% RH	0-10 V	-1 mA < I _L < 1 mA oder
	4-20 mA (two-wire)	R _L < 500 Ohm
Digital output*	RS485	
Working range	10...95% RH	
Accuracy at 20°C	±2.5% RH	
Temperature dependency	typ. ±0.03% RH/°C	

Temperature

Sensor	Pt1000 (tolerance class B, DIN EN 60751)
Analog output ¹⁾	0-10 V
	4-20 mA
Digital output*	Modbus RTU
T-Accuracy at 20°C	±0.3°C
passive T-output	see ordering code

General

Power supply	
for 0 - 10 V / RS485	15 - 35V DC or 24V AC ±20%
for 4 - 20 mA	10V + R _L x 20 mA < U _v < 35V DC
Current consumption	
Analog	with DC power supply typ. 5mA with AC power supply typ. 13mA _{eff}
Digital*	with AC power supply typ. 2mA
Connection	Screw terminals, max. 1.5 mm ²
Housing / protection class	Polycarbonate (UL listed) / IP65
Cable gland	M16 x 1.5
Sensor protection	membrane filter
Electromagnetic compatibility	EN61326-1 EN61326-2-3
Temperature ranges	Operating temperature: -15...60°C (5...140°F) Storage temperature: -25...60°C (-13...140°F)



* Available from Q4/2012

¹⁾ Output scaling see Ordering Guide

Dimensions (mm)

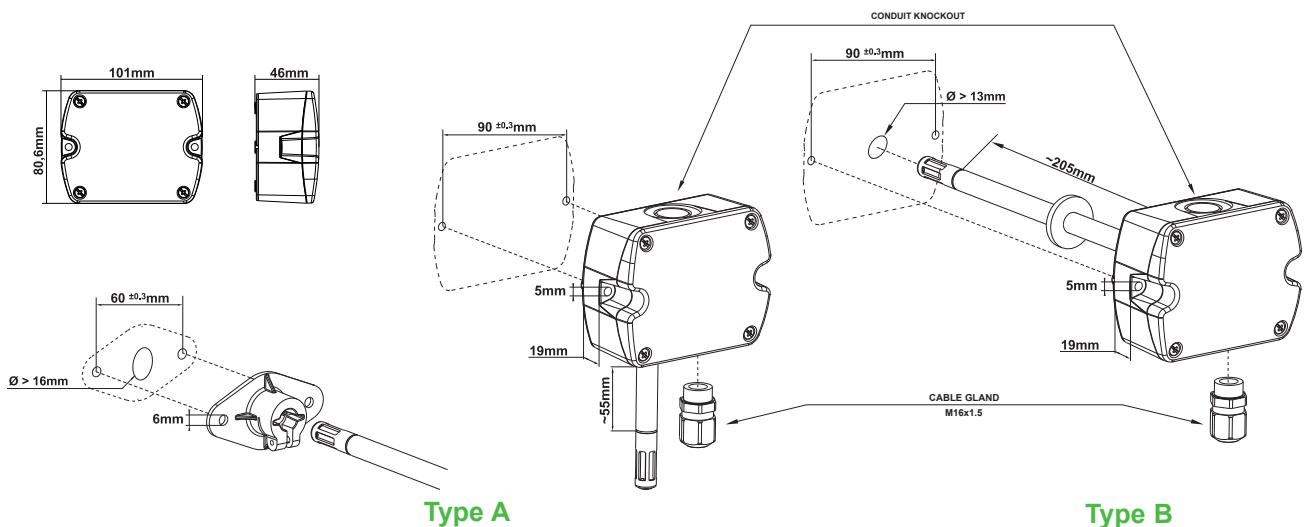

Connection diagram

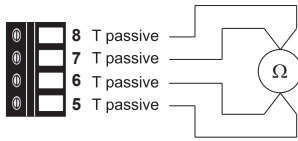

EE160-HT3xxx

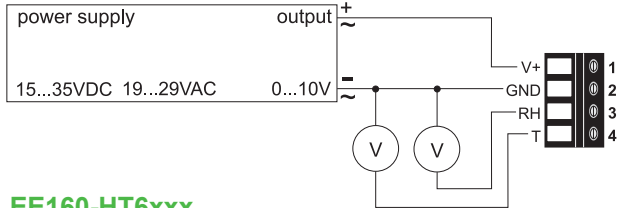

EE160-HT6xxx

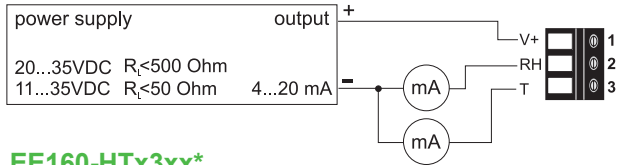

EE160-HTx3xx*

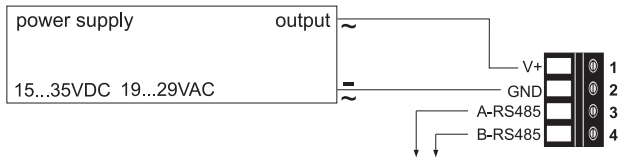

Ordering Guide

Configuration

MODEL	ANALOG ¹⁾	DIGITAL ^{1)*}	PASSIVE T-SENSOR ²⁾	HOUSING	TYPE	FILTER
humidity + temperature (HT)	0-10V (3)	RS485 (3)	Pt 100 DIN A (A)	polycarbonate (P)	wall mount (A)	membrane filter (B)
	4-20mA (6)	none (x)	Pt 1000 DIN A (C)		duct mount (B)	
	none (x)		NTC 10k (E)			
			none (x)			
EE160-						

Interface parameter - analog output

OUTPUT SCALING	SCALING	UNIT
temperature (Tx)	-30...40° (001)	metric (M)
	-40...60° (002)	non-metric (N)
	-10...50° (003)	
	0...50° (004)	
	other (xxx)	

Interface parameter - digital output*

PROTOCOL	BAUDRATE	PARITY	STOPBITS	UNIT
modbus (1)	9600 (A)	odd (O)	1 stopbit (1)	metric (M)
	19200 (B)	even (E)	2 stopbit (2)	non-metric (N)
	38400 (C)	no parity (N)		

¹⁾ a combination of analog and digital version is not possible ²⁾ analogue version only
 * Available from Q4/2012

Accessories

- EE160 Cable for configuration adapter (HA011059)*
 - Configuration adapter (HA011050)
- * only for EE160 analog version

Order example

Analog output

EE160-HT6xAPAB/Tx001M

Model: humidity + temperature transmitter
 Analog output: 4-20mA
 Passive T-Sensor: Pt 100 DIN A
 Housing: polycarbonate
 Type: wall mounting
 Filter: membrane filter

Output scaling: temperature
 Scaling: -30...40°
 Unit: metric

Digital output

EE160-HTx3xPBB/1AE1N

Model: humidity + temperature transmitter
 Digital output: RS485
 Housing: polycarbonat
 Type: duct mounting
 Filter: membrane filter

Protocol: Modbus
 Baudrate: 9600
 Parity: even
 Stopbits: 1
 Unit: non-metric