

Model LS 連桿式浮球開關

LEVEL SWITCH

MODEL LS

防爆接線盒 牙口 衛生夾接 法蘭

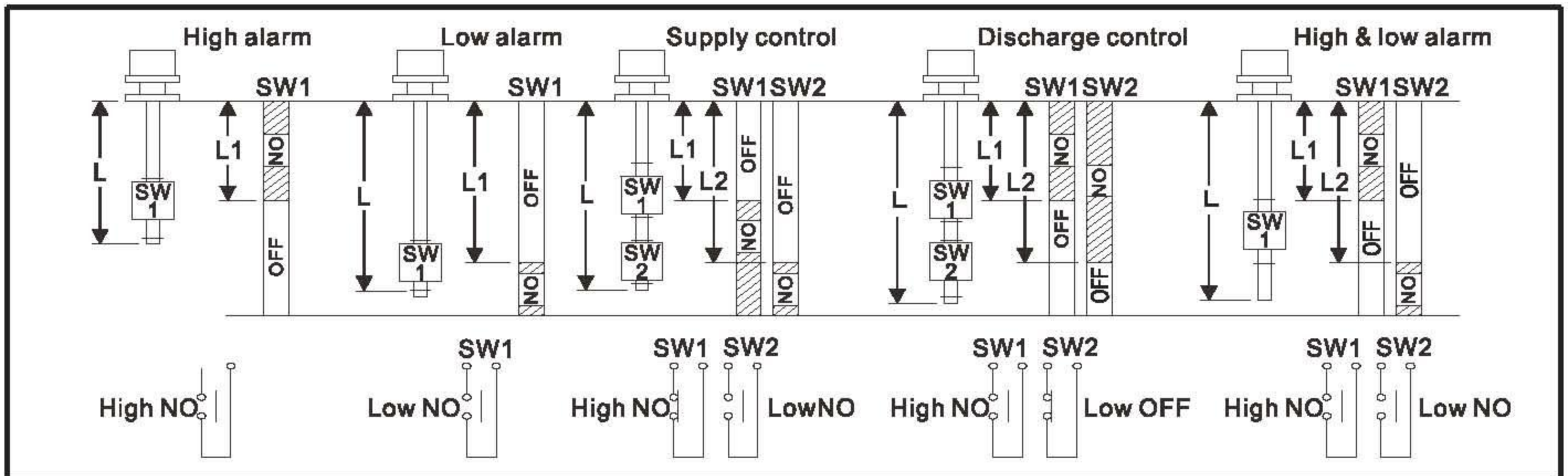
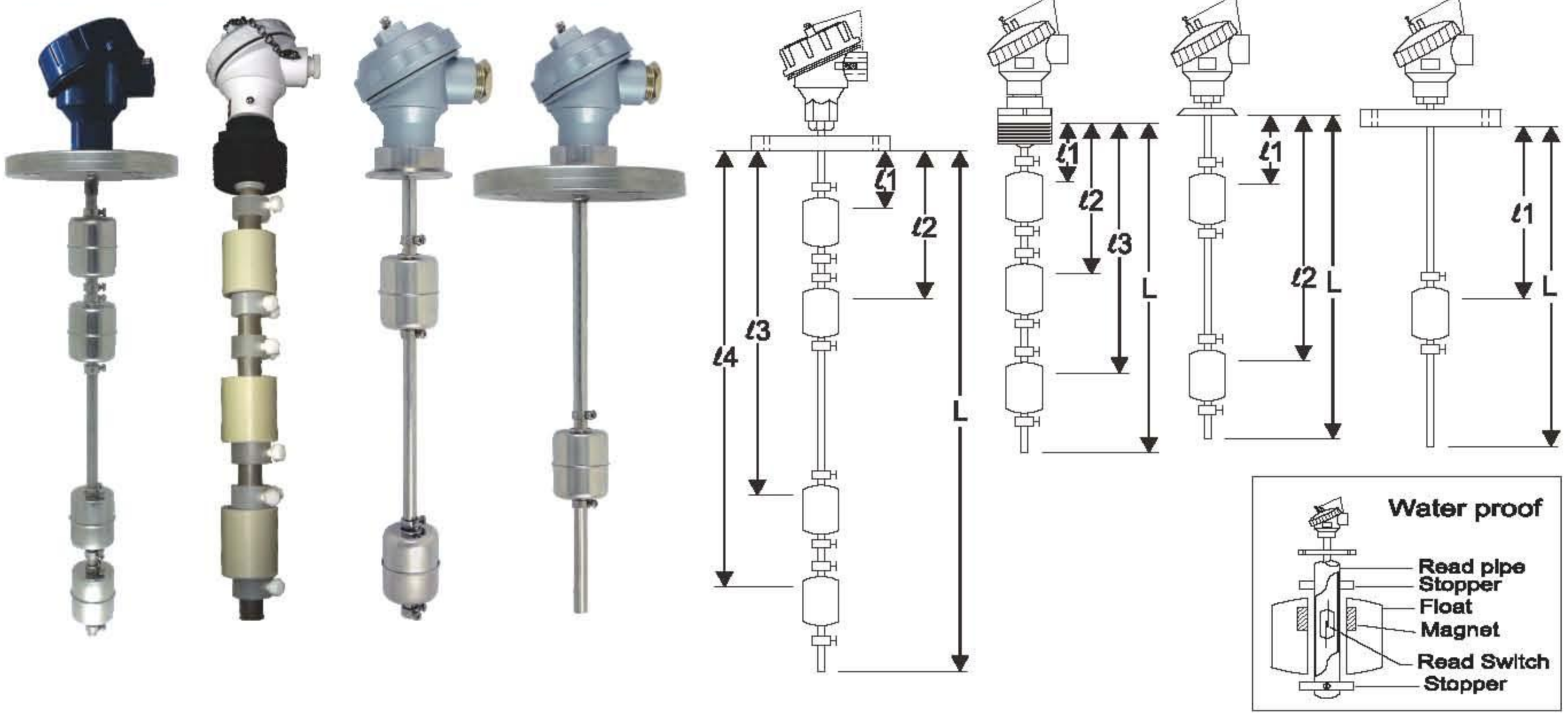

ORDERING INFORMATION

Body Material	Float Number	Connection Size	Connection Type	Terminal Box	Electrical Connection	Float Material	Alarm Type
P PP	1	40 1 1/2"	A ANSI 150LB	P PP	A 1/2"PT	A PP(Ø43mmx50L)	A NO
S SS304	2	50 2"	J JIS 10K	S SS304	B 3/4"PT	B PP(Ø56mmx63L)	B NC
W SS316	3	65 2 1/2"	P PT	W SS316	C 1/2"NPT	C PVDF(Ø60mmx53L)	C 1A1B
V PVC	4	80 3"	N NPT	A ALUMINUM	D 3/4"NPT	D 316(Ø26mmx24L)	
D P.V.D.F	5	100 4"	C 衛生夾接	D ALU. D2G4		E 316(Ø28mmx29L)	
C C.P.V.C				E 316 D2G4		F 316(Ø41mmx53L)	

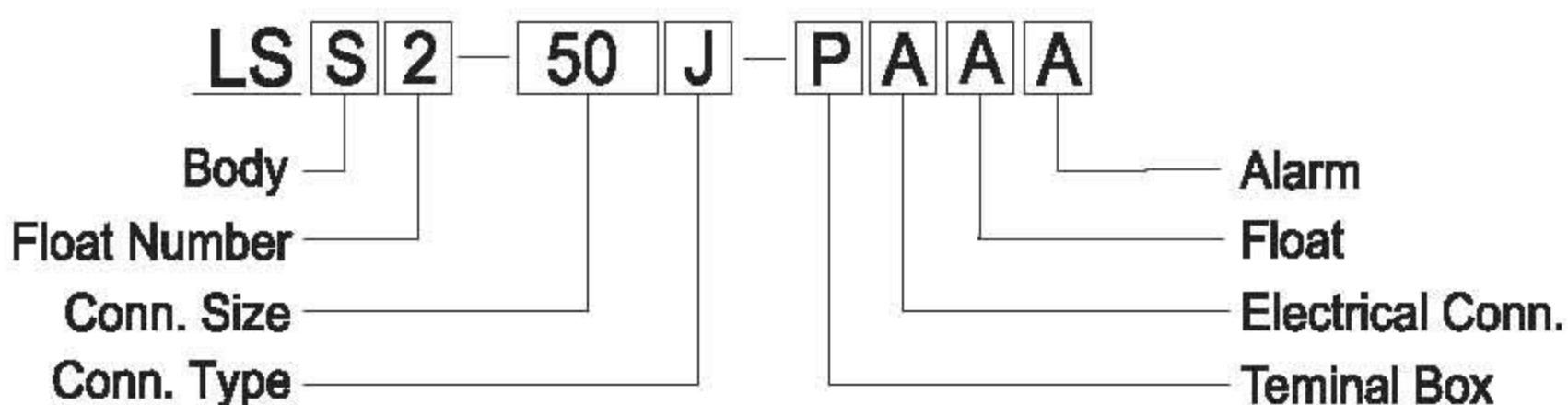

SPECIFICATIONS

Material	SUS	PVDF	PP	PVC
Max. Temp	100°C			50°C
Max. Press	10kg/cm ² G			5kg/cm ² G
Elec. Rating	1A@250V			